

CPHD-3

HDMI V1.3 Pattern Generator

Operation Manual



CPHD-3

• **Disclaimers**

The information in this manual has been carefully checked and is believed to be accurate. Cypress Technology assumes no responsibility for any infringements of patents or other rights of third parties which may result from its use.

Cypress Technology assumes no responsibility for any inaccuracies that may be contained in this document. Cypress also makes no commitment to update or to keep current the information contained in this document.

Cypress Technology reserves the right to make improvements to this document and/or product at any time and without notice.

• **Copyright Notice**

No part of this document may be reproduced, transmitted, transcribed, stored in a retrieval system, or any of its part translated into any language or computer file, in any form or by any means - electronic, mechanical, magnetic, optical, chemical, manual, or otherwise - without express written permission and consent from Cypress Technology.

© Copyright 2009 by Cypress Technology.
All Rights Reserved.
Version 1.0 July 2009

• **Trademark Acknowledgments**

All products or service names mentioned in this document may be trademarks of the companies with which they are associated.

• **Safety Precautions**

Please read all instructions before attempting to unpack or install or operate this equipment, and before connecting the power supply. Please keep the following in mind as you unpack and install this equipment:

- Always follow basic safety precautions to reduce the risk of fire, electrical shock and injury to persons.
- To prevent fire or shock hazard, do not expose the unit to rain, moisture or install this product near water.
- Never spill liquid of any kind on or into this product.
- Never push an object of any kind into this product through module openings or empty slots, as you may damage parts.
- Do not attach the power supply cabling to building surfaces.
- Do not allow anything to rest on the power cabling or allow it to be abused by persons walking on it.
- To protect the equipment from overheating, do not block the slots and openings in the module housing that provide ventilation.

• **Revision History**

<i>Version No</i>	<i>Date</i>	<i>Summary of Change</i>
<i>V1</i>	<i>20090803</i>	<i>Preliminary Release</i>

Table of Contents

1. Introduction.....	1
2. Applications.....	1
3. Features.....	1
4. Specifications.....	2
5. System Requirement.....	4
6. Package Contents.....	4
7. Control Panels.....	5
7.1 Front Pannel.....	5
7.2 Rear Pannel.....	7
8. Remote Control.....	8
9. Built-IN RX EDID Structure.....	10
10. RS-232 Connection and Protocol.....	10
11. Features of RS-232 PC Software.....	12
12. RS-232 PC Software Operation.....	13
13. Timing Table.....	14
14. Pattern Table.....	15
15. Description of Patterns.....	16
16. Firmware Revision History.....	21

1. Introduction

This HDMI v1.3 compliant video test pattern generator is the most advanced device for your audio & video signals test. With built-in 39 timings and 51 patterns that accept both analog and digital signals provide over thousand types of testing signals. This handy device can be conveniently controlled via the front panel buttons or the IR remote and a LCD screen for easy viewing. Other than testing your devices this generator can also check the resolution of your devices and record them, check bandwidth and phase behavior transmission, verify video amplifiers/color temperature/video motion plus HDCP verification, data comparison, EDID check and many more useful functions.

2. Applications

- Apparatus testing
- Equipment adjustment
- EDID check
- Source setting define
- HDCP verification

3. Features

- HDMI v1.3, HDCP v1.1 and DVI v1.0 compliant
- Provides 39 timings and 51 patterns
- Timing included SD, HD up to 1080p, PC up to UXGA/WUXGA (Reduce Blanking Pixel Rate at 154MHz)
- Patterns include Graphic Test Patterns and Data Analysis Patterns
- Output format with digital HDMI/DVI, or analog PC/HD (component)
- Color Space supports RGB444, YCbCr444 and YCbCr422
- Deep Color supports 8 / 10 / 12 bits
- Audio source is selectable among external 7.1CH, optical or internal sinewave
- Internal sinewave LPCM channel is selectable from 2CH, 5.1CH and 7.1CH
- Supports HDCP test
- Support EDID data analysis.
- Support HDMI/DVI input data analysis.
- Support Autorun function
- Choose [My Favorite] timings and patterns through RS-232 using PC software that included in the box.
- Friendly user interface - LCD display, LED indicators, IR remote and RS-232 remote

4. Specifications

39 Timings: 480 x 640 ~ 1366 x 768 (Details in TIMING TABLE)

SD timings: 480i , 480p, 576i and 576p

HD timings: 720p up to 1080p

PC timings: VGA up to UXGA, WUXGA (Reduce Blanking Pixel Rate at 154MHz)

- **NOTE** > Analog PC output only supports PC timings
Analog HD output only supports SD/HD timings
HDMI/DVI output support all timings
- **NOTE** > This system didn't support user timing editing

- **51 Patterns: (Details in PATTERNS TABLE)**

Graphic Test Patterns: 45 Patterns

Data Analysis Patterns: 6 Patterns

- **NOTE** > This system didn't support user pattern editing

- **HDMI/DVI Input & Output:**

Signal: TMDS single link and clock bandwidth up to 225MHz

Connector: HDMI TYPE-A. DVI input needs DVI to HDMI adaptor

- **Analog PC/HD Output:**

Signal: Analog R/G/B/H/V or analog YPbPr are support color space conversion.

Component HD outputs support tri-level sync and color space conversion.

Connector: D-SUB15. For HD component output, DB15 to 3-RCA adaptor cable is required.

- **Video Color Space and Deep Color:**

HDMI Output: RGB444(8/10/12bits), YCbCr444(8/10/12bits) and YCbCr422(8bits)

DVI Output:RGB444(8bits)

PC Output: RGB with separate sync H/V or

YPbPr with separate sync H/V and without composite sync on Y.

HD Output: YPbPr with composite sync on Y or RGB with composite sync on G.

- **Audio Inputs:**

External Analog 7.1CH: RCA jacks.

External Optical: Toslink jack.

Internal Sinewave:

Supports LPCM 2CH, 5.1CH and 7.1CH.

Supports Sampling Rate 48KHz, 96KHz and 192KHz (Refer to Audio Output)

Sinewave Frequency: FL (Front Left)=1000Hz, FR (Front Right)=600Hz, CNT (Center)=800Hz, SUB (Subwoofer)=400Hz, SL (Surround Left)=1200Hz, SR¹ (Surround Right)=1400Hz, SBL (Surround Back Left)=1600Hz, SBR (Surround Back Right)=1800Hz

➤ **NOTE>** This system didn't support bitstream (Dolby, DTS) decoding from external optical.

- **Audio Output:**

Analog 7.1CH: RCA jacks.

Optical: Toslink jack.

Coaxial: RCA jack.

HDMI: Support I2S bus control.

Pattern 38: Audio control functions please refer to below table.

(SR¹=Samping Rate)

2CH: FL (Front Left) and FR (Front Right). 6CH: FL (Front Left), FR (Front Right), CNT (Center), SUB (Subwoofer), SL (Surround Left) and SR² (Surround Right)

INPUT \ OUTPUT	Analog 7.1CH	OPTICAL/COAX	HDMI
Ext. 7.1CH	Bypass	LPCM 2CH SR ¹ :48KHz	LPCM 2CH, 6CH SR ¹ :48KHz
Ext. OPTICAL	2CH	Bypass	Bypass
Int. Sinewave	2CH, 6CH, 8CH	LPCM 2CH SR ¹ :48KHz	LPCM 2CH, 6CH, 8CH SR ¹ :48K, 96K, 192KHz Only support 2CH for SR ¹ 96KHz under 480i/p, 576i/p,VGA60. Only support 2CH for SR ¹ 192KHz

- **Pattern 32 - EDID Analysis:**

The EDID sources can form three different ways and support 2 block analysis. The system will copy the Sink EDID and built-in into Rx EDID to analysis display information.

Below are the three different ways to get the EDID:

1. Built-in Rx EDID
2. From Display HDMI/DVI Sink EDID
3. From Display VGA EDID

The EDID analyses are follow VESA E-EDID v1.3 and EIA/CEA 861D Version 3 standard.

- **Pattern P39 - HDCP Analysis:**

This system will do the HDCP handshaking and link-integrity test and it also support Sink Repeater BKSv list and V' values.

- **HDMI/DVI Input Analysis:**

Support manual Hot-plug (Press [OPTION])

Pattern 48: HDMI/DVI Video Timing Detection and Analysis

Pattern 49: HDMI/DVI Video Packets and Infoframe Detection and Analysis.

Pattern 50: HDMI Audio Packets and Infoframe Detection and Analysis.

- **User Interface:**

LCD display, LED indicators, IR remote,

RS-232 remote: D-SUB9 female connector.

PC software supports RS-232 remote control.

5. System Requirement

Video and or audio source input with connecting cables and output display and or speaker(s) with connecting cables.

6. Package Contents

- HDMI V1.3 Pattern Generator
- Power Adaptor
- Remote Control
- Operational Manual

7. Control Panels

7.1 Front Panel

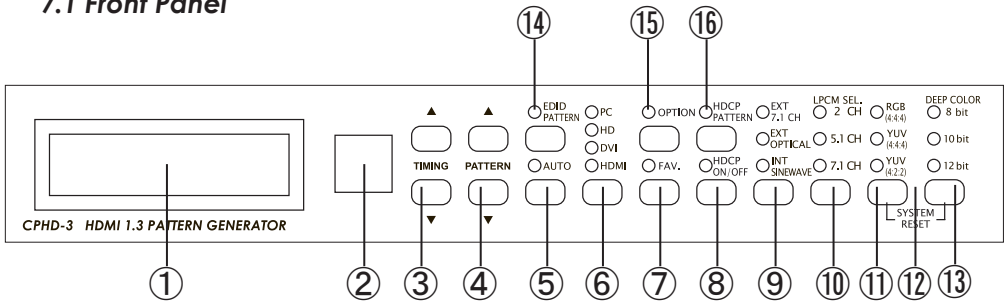

①

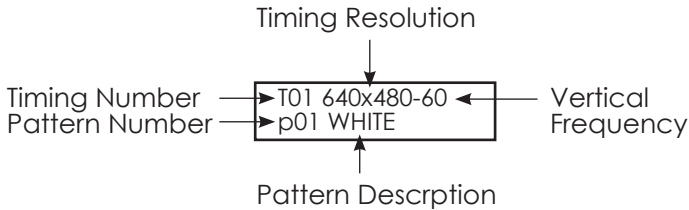

② IR Remote Control Sensor.

③ Timing Selection: Switch between timings from T01 to T39.

④ Pattern Selection: Switch between patterns from P01 to P51.

For some patterns, it supports OPTION function. After enter option function and then press Pattern up/down button to adjust the Brightness level.

⑤ AUTO: Turn ON/OFF Autorun Demonstration Function.

Using PC software through RS-232, users can select timings among T01~T39 and patterns among P01~P51 for Autorun demonstration. When Autorun is turn on, the systems will automatically running the selection timings/patterns sequentially.

⑥ Output Format Selection: Press the button to switch between PC, HD, DVI and HDMI output.

⑦ FAV.: Turn ON/OFF Favorite Function.

When switch on the Favorite function, users can select only the favorite timings and favorite patterns. Users need to select favorite timings among T01~T39 and favorite patterns among P01~P51 by using PC software through RS-232.

When switch off the Favorite function, users can select all the timings and patterns.

- ⑧ HDCP ON/OFF: Turn ON/OFF the HDCP encryption. When the LED illuminate it means the HDCP encryption is on.
- ⑨ Audio Source Selection: Press the button to switch between External 7.1CH(analog), external optical(digital) or internal sinewave audio source.
- ⑩ LPCM Channel Selection: Press the button to switch between 2CH, 5.1CH or 7.1CH LPCM audio channels.
- ⑪ Color Space Selection: Press the button to switch between RGB444, YCbCr444 or YCbCr422 color space.
- ⑫ System Reset: Press two buttons at the same time to reset the system back to factory mode. During the system reset the LCD Display will show "SYSTEM RESET" message.
- ⑬ Deep Color Selection: Press the button to switch between 8bits, 10bits or ① bits deep colors.
- ⑭ EDID Pattern: Pattern 32 hot key.
- ⑮ OPTION: Not all the Patterns support function adjustments, when screen shows "Press [OPTION] to do the setting" that means this pattern support function adjustment. When user press the OPTION button the LED will illuminate and then press Pattern +/- button to adjust the Brightness level. Switch off the OPTION function before go to next pattern selection.
- ⑯ HDCP Pattern: Pattern 39 hot key.

7.2 Rear Panel

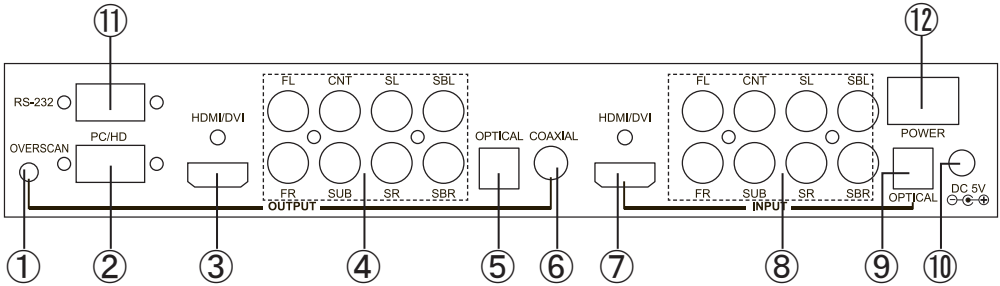

- ① OVERSCAN: When output timing is 480i59/60, 480p59/60, 576i50 or 576p50, the output signal may not showing full image on the screen, press the OVERSCAN button to fill screen completely.
When signal under OVERSCAN mode, the LCD Display will show STAR (*) sign at the end of the timing resolution string. Press OVERSCAN to turn off the overscan mode and the STAR (*) sign will disappear.
- ② PC/HD Output: Connect VGA cable to the VGA monitor for analog PC timing or HD timing signal output.
- ③ HDMI/DVI Output: Connect HDMI or DVI cable to the HDMI or DVI display.
- ④ 7.1CH Output: Connect 7.1CH to the speaker or Audio Video Receiver.
The audio printed definition as below:
FL:Front Left, FR:Front Right, CNT:Center, SUB:Subwoofer, SL:Surround Left
SR:Surround Right, SBL:Surround Back Left, SBR:Surround Back Right.
- ⑤ OPTICAL Output.
- ⑥ COAXIAL Output.
- ⑦ HDMI/DVI Input: Connect HDMI or DVI Input source to the system.
- ⑧ 7.1CH Input: Analog 7.1CH Inputs.
- ⑨ OPTICAL Input
- ⑩ Power Input: Plug 5V DC power adaptor.
- ⑪ RS-232 Connection: Connect RS-232 cable between this system and PC.
Using PC software to control this system through RS-232 port.
- ⑫ Power Switch: Turn ON/OFF the system.

8. Remote Control

- ① HDCP ON/OFF: Turn ON/OFF HDCP encryption.
- ② Color Space Selection: Switch between RGB444, YCbCr444 or YCbCr422.
- ③ Output Timing Selection
- ④ OUTPUT ON: Turn ON/OFF the option function.
- ⑤ Timing - : Backward Timing Selection.
- ⑥ AVMUTE ENABLE: For HDMI output, press to mute the Audio. The LCD Display will show "AVMUTE ON".
- ⑦ AUDIO: Switch between External 7.1CH(analog), external optical(digital) or internal sinewave.
- ⑧ EDID: Pattern 32 hot key.
- ⑨ Output Format Selection: Switch between PC, HD, DVI or HDMI output.
- ⑩ Output OFF: Switch off the output signal. The LCD Display will show "OUTPUT OFF".
- ⑪ Pattern +: Next Pattern Selection. For some patterns, it supports OPTION function. After entering into option function and then press Pattern up/down buttons to adjust the Brightness level.
- ⑫ Timing +: Nex Timing Selection.
- ⑬ OPTION(OK): Not all the Patterns support function adjustments, when screen shows "Press [OPTION] to do the setting" that means this pattern support *function adjustment*. When user press the OPTION button the LED will illuminate and then press Pattern +/- button to adjust the Brightness level. Switch off the OPTION function before go to next pattern selection.
- ⑭ AVMUTE DISABLE: For HDMI output, press to mute the Audio. The LCD display will show "disable AVMUTE".
- ⑮ Pattern -: Backward Pattern Selection. For some patterns, it supports OPTION function. After enter option function and then press Pattern up/down button to adjust the Brightness level.

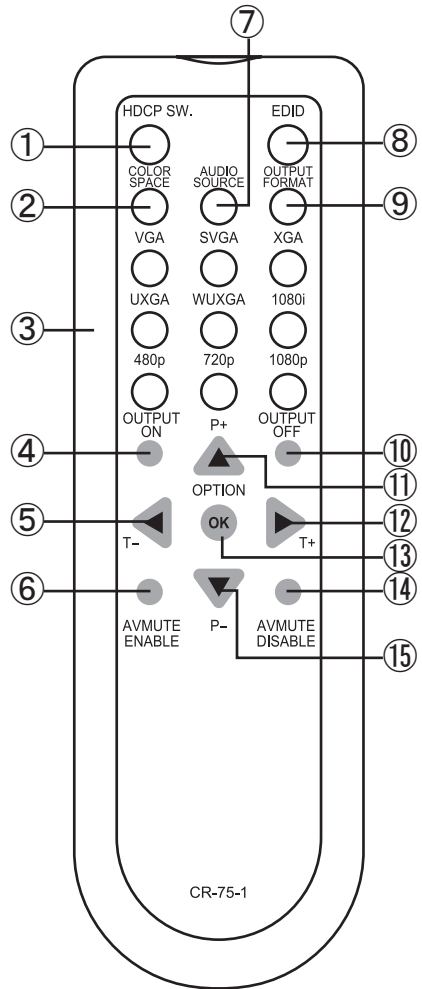

➤ **Note**> Open remote control cover of battery, using dip-switch to set controller address.

9. Built-In Rx Edid Structure:

- The system support 4 sets Built-in Rx EDID, one is active and others are for backup.
- The Active EDID will copy the EDID from backup EDID. (Go to "System Setup" function)
- The system will copy the Sink EDID and built-in into Rx EDID to analysis display information.
- RS-232 PC software programs can support Rx EDID contents.

10. RS-232 Connection and Protocol:

- Connection between the unit and remote controller with RS-232 modem cable (No Wire Crossing).

Pin definition

System			Remote Controller	
PIN	Definition		PIN	Definition
1	NC		1	NC
2	TxD	→	2	RxD
3	RxD		3	TxD
4	NC	←	4	NC
5	GND		5	GND
6	NC		6	NC
7	NC		7	NC
8	NC		8	NC
9	NC		9	NC

- RS-232 transmission formats:
Baud Rate=19200bps
Data Bit=8bits
Parity=None
Stop Bit=1bit
Flow Control=None

● Command / Response codes of RS-232 transmission:

Command	Description	CPHD-3 Response(note 1)
ASC001 ASC002 ASC003 ASC999	Audio source is from external L/R Audio source is from external OPTICAL Audio source is from internal Sinewave Inquire audio source status	ASC001 ASC002 ASC003 ASC???
ATO000 ATO001 ATO999 ATN???	set Autorun Off set Autorun On Inquire Autorun Action status Autorun Number, ???=001~032	ATO000 ATO001 ATO??? ATNxxx (note 2)
ATT??? ATP??? ATI??? ATS999	Autorun Timing, ???=001~039 Autorun Pattern, ???=001~051 Autorun time Interval, ???=005~600 seconds Inquire Autorun Configuration status	ATTxxx ATPxxx ATIxxx ATNxxx + ATIxxx + ...
CRR??? CRG??? CRB??? CRY??? CRR999 CRG999 CRB999 CRY999	Color Setting Red or Cr, ???=000~255 Color Setting Green or Y, ???=000~255 Color Setting Blue or Cb, ???=000~255 Color Setting Gray, ???=000~255 Inquire Color Setting Red or Cr status Inquire Color Setting Green or Y status Inquire Color Setting Blue or Cb status Inquire Color Setting Gray	CRRxxx CRGxxx CRBxxx CRYxxx CRR??~/CRR300 (note 3) CRG??~/CRG300 CRB??~/CRB300 CRY??~/CRY300
CSC001 CSC002 CSC003 CSC999	Color space is RGB444 Color space is YUV444 Color space is YUV422 Inquire color space status	CSC001 CSC002 CSC003 CSC???
DEE001 DEE002 DEE003 DEE999	Deep Color is 8 bit Deep Color is 10 bit Deep Color is 12 bit Inquire Deep Color status	DEE001 DEE002 DEE003 DEE???
ESC001 ESC002 ESC003 ESC004 ESC005 ESC006	EDID source is from TX (HDMI/DVI out) EDID source is from RX (built-in Active EDID) EDID source is from RX1 (built-in EDID1) EDID source is from RX2 (built-in EDID2) EDID source is from RX3 (built-in EDID3) EDID source is from VGA (PC/HD out)	ESC001 ESC002 ESC003 ESC004 ESC005 ESC006
ERX00? "Name String" ERX99?	set RX1,RX2 or RX3 EDID name. ?=1~3 EDID name string, string length is 12 byte Inquire RX1,RX2 or RX3 EDID name. ?=1~3	ERX00? (note 4) ERX004 (note 5) ERX99? + "?????????????"(note 6)
ERD001 ERS001 EWR001	Read sink's EDID Erase sink's EDID and fill with 'FF' Write EDID to sink	ERD001, datastream (note 7) ERS001, ERS002/ERS003 (note 8) EWR001, EWR002/EWR003 (note 9)
FAV000 FAV001 FAV999	set My Favorite Off set My Favorite On Inquire My Favorite action status	FAV000 FAV001 FAV???

FP+???	Add Favorite PATTERN, ???=001~051	FP+xxx
FP-???	Drop Favorite PATTERN, ???=001~051	FP-xxx
FP+999 or FP-999	Inquire Favorite PATTERN status	FP+???
FT+???	Add Favorite TIMING, ???=001~039	FT+xxx
FT-???	Drop Favorite TIMING, ???=001~039	FT-xxx
FT+999 or FT-999	Inquire Favorite TIMING status	FT+???
HDC000	set HDCP Off	HDC000
HDC001	set HDCP On	HDC001
HDC999	Inquire HDCP status	HDC???
MOT001	set Pattern 46.Motion's custom string.	MOT001 (note 10)
"Custom String"	Custom string, string length is 12 byte	MOT002 (note 11)
MOT999	Inquire Motion Pattern's custom string	MOT999 + "????????????"(note 12)
OUT001	Select output format [PC]	OUT001
OUT002	Select output format [HD]	OUT002
OUT003	Select output format [DVI]	OUT003
OUT004	Select output format [HDMI]	OUT004
OUT999	Inquire output format status	OUT???
PAT???	Select PATTERN P01~P50, ???=001~051	PATxxx
PAT999	Inquire PATTERN status	PAT???
PCM001	set LPCM 2CH	PCM001
PCM002	set LPCM 5.1CH	PCM002
PCM003	set LPCM 7.1CH	PCM003
PCM999	Inquire LPCM Channel status	PCM???
RST001	System reset	RST001
TIM???	Select TIMING T01~T39, ???=001~039	TIMxxx
TIM999	Inquire TIMING status	TIM???
VER999	Inquire firmware version.	VER???(Ex:VER021=V2.1)

note 1: After computer sends command to the system, computer has to wait for response from the system.

Then computer can send next command to the system.

If this system is under autorunning, RS-232 communications maybe fail.

note 2: To configurate Autorun follows a sequence of commands --- ATNxxx + ATTxxx + ATPxxx + ATlxxx ...

note 3: If this system is not on Pattern 47.Color Setting, respond CRR300, CRG300, CRB300 or CRY300.

note 4: Procedure of setting RX EDID name string :

send "ERX00?" -> wait "ERX00?" response -> send name string (12 bytes)
-> wait "ERX004"

note 5: In the name string, the rest unused bytes (<12bytes) should be filled with 0x00.

- note 6: After ERX99? response, name string (12 bytes) is followed.
- note 7: After ERD001 response, this system reads sink's EDID and transmits them (datastream) to remote terminal
If this system reads sink's EDID fail, the system sends '0xfe' and stop datastream.
This system supports 2-block EDID, datastream length=block0+block1=256 bytes
- note 8: After ERS001 response, this system erases sink's EDID and fill with 'FF'.
After erase completely, the system reponses ERS002
If erase fail, the system responses ERS003
- note 9: After EWR001 response, this system will waits for EDID datastream(256 bytes) from PC After receive datastream completely, the system writes datastream to sink. If write successfully, the system responses EWR002, otherwise EWR003
- note 10: Procedure of setting custom string :
send "MOT001" -> wait "MOT001" response -> send custom string (12 bytes) -> wait "MOT002"
- note 11: In the custom string, the rest unused bytes (<12bytes) should be filled with 0x00. Custom string supports English language only.
- note 12: After MOT999 response, custom string (12 bytes) is followed.

11. Features of RS-232 PC Software

- Click button and upload selected timing or pattern.
- Select [My Favorite] timings and patterns.
- Read out EDID contents from sink.
- Write EDID contents to sink.
- Can be an EDID burner.
- Analyze EDID data and generate a report file.
- Configure Autorun [AUTO] List.
- Panel Controls through RS-232
- Monitors System status.
- Edit custom string of Motion Pattern (Pattern 46).
- Adjust color-levels pattern (Pattern 47).

12. RS-232 PC Software Operation

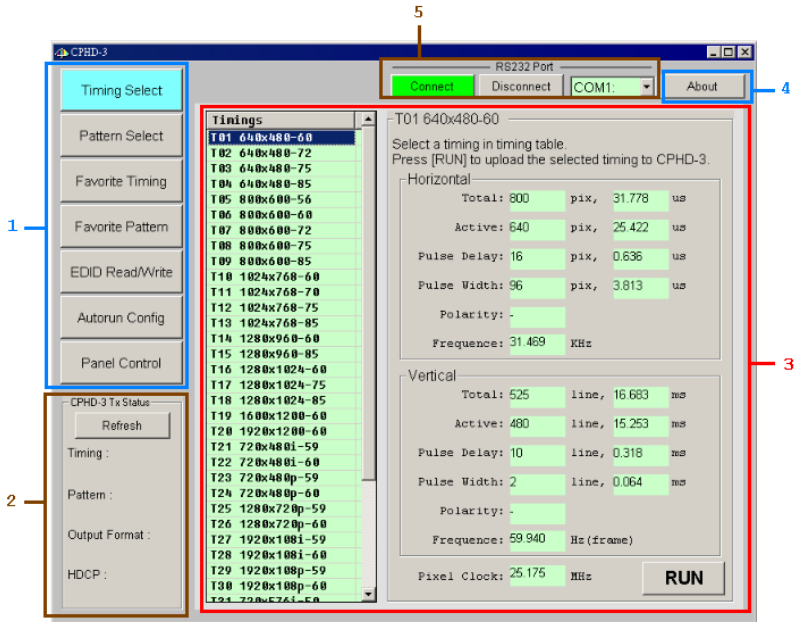

① Main Function Selection:

Timing Select: Select a timing among T01~T39

Pattern Select: Select a pattern among P01~P51

① Favorite Timing: Select favorite timings among T01~T39

Favorite Pattern: Select favorite patterns among P01~P51

EDID Read/Write: Read, write EDID contents and analyze EDID data.

Autorun Config: Configure autorun list.

Panel Control: Control system functions.

② Status Monitor: Click [Refresh] button to get system status.

③ Work Area: Different main functions have independent work area.

④ About: Get PC software and system firmware version number.

⑤ RS-232 Setup: Select RS-232 Comport and turn on/off connection.

13. Timing Table









No.	Resolution	V Hz	No.	Resolution	V Hz
T01	640x480	60	T21	720x480i	59
T02	640x480	72	T22	720x480i	60
T03	640x480	75	T23	720x480p	59
T04	640x480	85	T24	720x480p	60
T05	800x600	56	T25	1280x720p	59
T06	800x600	60	T26	1280x720p	60
T07	800x600	72	T27	1920x1080i	59
T08	800x600	75	T28	1920x1080i	60
T09	800x600	85	T29	1920x1080p	59
T10	1024x768	60	T30	1920x1080p	60
T11	1024x768	70	T31	720x576i	50
T12	1024x768	75	T32	720x576p	50
T13	1024x768	85	T33	1280x720p	50
T14	1280x960	60	T34	1920x1080i	50
T15	1280x960	85	T35	1920x1080p	50
T16	1280x1024	60	T36	1920x1080p	23
T17	1280x1024	75	T37	1920x1080p	24
T18	1280x1024	85	T38	1366x768	60
T19	1600x1200	60	T39	1366x768	50
T20	1920x1200	60			

14. Pattern Table

- Graphic Test Patterns: 45 Patterns
- Data Analysis Patterns: 6 Patterns (Include P32, P38, P39, P48, P49, P50)

P01 WHITE	P24 MULTI-BURST
P02 BLUE	P25 Pluge
P03 RED	P26 GRID-1
P04 MAGENTA	P27 GRID-36
P05 GREEN	P28 GRAY-256-R
P06 CYAN	P29 GRAY-256-G
P07 YELLOW	P30 GRAY-256-B
P08 BLACK	P31 CIRCLES
P09 RED Setting	P32 EDID
P10 GRN Setting	P33 H Grey Scale
P11 BLUE Setting	P34 Hori.RGB Bar
P12 GRAY Setting	P35 SMPT Bar
P13 COLOR BAR	P36 Split Bar
P14 GRAY-8	P37 CROSS HATCH
P15 GRAY-16	P38 AUDIO
P16 GRAY-32	P39 HDCP
P17 GRAY-64	P40 Win Blue
P18 GRAY-256	P41 Win Red
P19 V line ONOFF	P42 Win Magenta
P20 BW-12	P43 Win Green
P21 H line ONOFF	P44 Win Cyan
P22 HOR.-3	P45 Win Yellow
P23 HOR.-6	P46 Motion
	P47 Color Setting
	P48 Rx Timing
	P49 Rx Video
	P50 Rx Audio
	P51 RGB Delay
	System Setup





15. Description of Patterns

GROUP	NO.	PATTERN	DESCRIPTION
Full Screen Purity	P01		Purity pattern Purity offers eight different full field patterns: Black, White (100% Y) Primary colors: Red, Green, Blue
	P02		Complementary colors: Magenta, Yellow, Cyan
	P03		P01: White P02: Blue P03: Red
	P04		P04: Magenta P05: Green P06: Cyan
	P05		P07: Yellow P08: Black
	P06		
	P07		
	P08		
Application			
<ol style="list-style-type: none"> 1. The red and green patterns are most frequently used for checking color purity. The red pattern is selected only this color should be visible; the presence of any other color is an indication that color purity needs adjustment. 2. The green pattern provides a purity check for three in-line tubes. In the in-line tubes, the guns are in a horizontal position and the green gun is located in the center. 3. The blue is the complementary colors are often used to check the color performance. 4. The red are used to ensure that there is no interference between the sound and chroma carrier. Furthermore the red pattern is used to adjust the long play delay level to minimum flicker. 5. In addition to the primary and complementary colors 100% white can be selected as well as black pattern with color burst to check. 			

Color Setting	P09 Red Setting P10 Green Setting P11 Blue Setting P12 Gray Setting	Press [OPTION],[PATTERN +/-] to adjust color level. There are 11 steps to adjust color level: 0, 25, 51, 76, 102, 127(default), 153, 178, 204, 229 and 255.
	P47 Color Setting	Through RS-232 PC software to adjust each color component value.

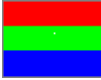

Application







This pattern is for brightness control and luminance writing current. This can overall the color performance, amplitude response/resolution and linearity of chroma amplitude.

Color Bar	P13		8 Bars
	P34		Hori. RGB Bar
	P35		SMPTE Color Bar
	P36		Split Color Bar
	P51		RGB Delay

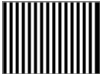
Application

The Color matrix test is to test for fixed quantity of color. To sum up, test for R, G, B color bar.









Gray Scale	P14		8 steps
	P15		16 steps
	P16		32 steps
	P17		64 steps
	P18		256 steps
	P33		H Gray Scale



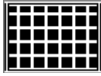

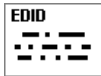

Application			
This is used to locate faulty linearity of the video amplifier or greyscale setting. Nonlinearities mainly result in a compression of the white level.			
Black White Line	P19		Vertical BW1 (black 1 pixel, white 1 pixel)
	P20		Vertical BW12(black 12 pixels, white 12 pixels)
	P21		Horizontal BW1(black 1 pixel, white 1 pixel)
	P22		Horizontal BW3(black 3 pixels, white 3 pixels)
	P23		Horizontal BW6(black 6 pixels, white 6 pixels)
	P24		Multi-Burst BW6+BW3+BW2+BW1

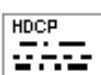
Application		
<p>The Vertical pattern serves for a quick check of a color monitor's horizontal bandwidth and phase behavior of a video transmission. It also, verify video amplifier and color temperature.</p> <p>The Horizontal pattern serves for a quick check of color monitor's vertical bandwidth and phase behavior of a video transmission. It also, verify video amplifier and color temperature.</p>		

PLUGE	P25		Picture Line-Up Generation Equipment Press [OPTION] to select color range Full Range=0~255, Limited Range=16~235 PC/HD output gets Full Range=0%~100%
-------	-----	---	---

Application		
<p>PLUGE is used to perform accurate and consistent line-up of picture monitors. The usual procedure is to adjust the brightness control of a monitor so that bar 1 is invisible on the background while bar 2 can be still distinguished. The white level luminance is mainly adjusted by the contrast control to 70 ± 10 cd/m² by means of the upper 100% white area of the vertical grayscale.</p>		

Grid	P26		1x1 (pixel) checkerboard
	P27		36x36(pixels) checkerboard
	P37		Cross Hatch Press [OPTION] to inverse black/white.
Application			
This pattern is mainly used for checking and aligning dynamic and corner convergence of TVs or monitors.			
Gradient	P28		Red Gradient
	P29		Green Gradient
	P30		Blue Gradient
Application			
This is used to locate faulty linearity of the video amplifier. Nonlinearities mainly result in a compression of the color level.			
Circle	P31		Circles
Application			
It's suited for checking the overall linearity and geometry of the screen of a monitor or TV.			
EDID	P32		EDID Analysis Press[OPTION],[PATTERN -/+] to analyze sink's EDID contents.
Audio	P38		Audio Control Source, Channel Number, Sampling Rate, I2S Controls
HDCP	P39		HDCP handshaking and link-integrity test If sink is a repeater, press [OPTION] to show BKSv List / V' value.

Window Purity	P40		75% of Height/Width Window Pattern.
	P41		
	P42		
	P43		
	P44		
	P45		





Application

The Monitor is controlled by electromagnetism which is made at the monitor. If the magnetism is made from monitor, distortion condition can be appeared because monitor is controlled by electromagnetism. If there isn't any distortion condition, we say, that monitor has good condition related by the 75% color purity.

Motion	P46		Font base motion test. Press [OPTION] to select motion object. Through RS-232 PC software, edit custom string.
	Application		

Application

This test pattern can be used to check the correct digital video processing, especially AD conversion of modern TV equipment. Moving pictures or slow motion function can be checked on VCRs by the pattern.

Rx Data Analysis	P48		HDMI/DVI input timing detection and analysis. Press [OPTION] to pull hot-plug NOTE> The values below are approximation. Pixel Rate, Horizontal Frequency, Vertical Frequency Those are for reference only.
	P49		HDMI/DVI input video packets and infoframes detection - and analysis. Press [OPTION] to pull hot-plug
	P50		HDMI input audio packets and infoframes detection and analysis. Press [OPTION] to pull hot-plug
Sys Setup			System Setup Built-in Rx EDID setup, IR remote address setup.

16. Firmware Revision History

Version	Release Date	Description
v1.0	2009.06.19	First release
v1.1	2009.07.xx	Add pattern 51-RGB Delay.

Acronyms

A



CYPRESS TECHNOLOGY CO., LTD.
Home page: <http://www.cypress.com.tw>

20090811 MPM-CPHD3